







Ls4.C: Adaptation

Base your answers to questions 1 on the information and chart below and on your knowledge of biology.

The Galapagos Islands are home to many different species of finches. Three finch species, their relative beak sizes, and their food preferences are represented below. All three species live on the same island.

Three Galapagos Finches and Their Sources of Nutrition

Name	Foods
Vegetarian finch <i>Platyspiza crassirostris</i> 	Buds, leaves, fruit of trees 
Warbler finch <i>Certhidea olivacea</i> 	Flying and ground-dwelling insects 
Cactus finch <i>Geospiza scandens</i> 	Cactus flowers and nectar 

- Which process allows for the evolution of finches over time?
 - natural selection
 - selective breeding
 - asexual reproduction
 - ecological succession
- A variety of species of Galapagos finches evolved from one original species long ago through the process of
 - asexual reproduction
 - ecological succession
 - natural selection
 - selective breeding
- Which characteristic is necessary for natural selection to occur in a species?
 - stability
 - variation
 - complex cellular organization
 - a very low mutation rate

4 The diagram below represents the relationship between natural selection and variation. The arrow between them is labeled X.

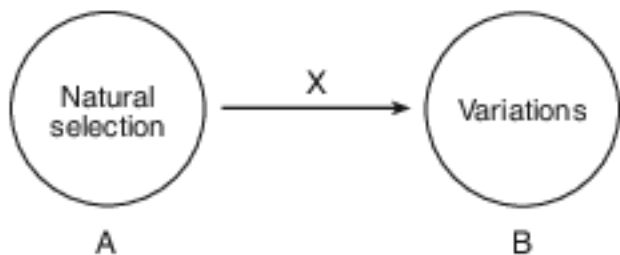

Which phrase best indicates the meaning of the arrow labeled X?

- (1) is dependent on
- (2) increases the rate of
- (3) decreases the rate of
- (4) is independent of

5 Some evolutionary pathways are represented in the diagram below.

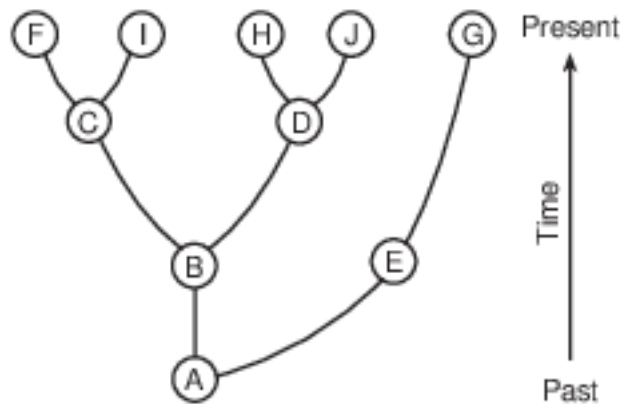

An inference that can be made from information in the diagram is that

- (1) species E evolved from species G
- (2) species A was probably much larger than all the other species
- (3) species C is a direct descendant of species I
- (4) species J is adapted to the existing environment

6 Which factor would be least likely to contribute to the development of a new species?

- (1) plentiful resources within the environment occupied by the species
- (2) increased genetic variation within the species
- (3) changes in the environment of the species
- (4) the ability of the species to increase its numbers by sexual reproduction

Base your answers to questions 7 on the information and table below and on your knowledge of biology.

Prey selection in a species of California garter snake depends upon where the snake lives. Snakes living inland feed on frogs, leeches, and fish while coastal snakes have added banana slugs to their diet. Banana slugs are found only in coastal areas. Researchers performed an experiment to determine what prey newly born snakes preferred. The table below summarizes the findings.

Prey Preference in Newborn Garter Snakes

	Newborn Coastal Snakes	Newborn Inland Snakes
Percentage of Snakes Eating Banana Slugs	60%	20%

- 7 Which inference best explains these differences?
- (1) The coastal snakes have been selectively bred for slug-eating behavior.
 - (2) Genetic manipulation has enabled the coastal snakes to recognize slugs as prey.
 - (3) The coastal snakes evolved a new organ so that they could recognize and feed on slugs.
 - (4) An adaptation enabled coastal snakes to use slugs as food source.

- 8 Genetic recombination, production of more offspring than can survive, and struggling with the challenges of the environment are all concepts associated with
- (1) natural selection
 - (2) mitotic division
 - (3) selective breeding
 - (4) genetic engineering

9 The table below shows adaptations in two organisms.

Environmental Adaptations		
Organism	Environment	Adaptation
desert rat	hot and dry	comes out of burrow only at night
Arctic poppy plant	cold and windy	grows low to ground next to rocks

The presence of these adaptations is most likely the result of

- (1) reproductive technology
- (2) natural selection
- (3) asexual reproduction
- (4) human interference

Base your answer to question 10-14 on the information below and on your knowledge of biology.

New varieties of organisms have resulted from human activities. These organisms have often led to problems in modern society. Two of these new varieties are listed below.

Antibiotic-resistant bacteria Pesticide-resistant insects

10-14 Select one of these varieties and discuss a problem associated with the development of this new variety of organism. In your answer, be sure to:

- identify the variety you selected
- identify one biological process by which a population of this variety may develop resistance [1]
- describe how this process is involved in the production of a population of resistant organisms [1]
- identify one problem caused by this resistance [1]
- state one solution to this problem [1]
- identify one possible negative effect of this solution [1]

Variety: _____

Base your answers to questions 15 on the information below and on your knowledge of biology.

EVOLUTION OF THE ELEPHANT

Today's elephants are the result of a long process of evolution. Over millions of years, small changes were passed from one generation to the next. The first fossil elephant species were small, but over time, they increased both in size and weight. The three species alive today are the sole survivors of a once much more widespread group.

Source: www.factmonster.com/dk/science/encyclopedia/evolution.html

15 Explain why some elephant species did not survive. [1]

Base your answers to question 16-18 on the information below and on your knowledge of biology.

Reindeer Drool

The results of new research highlight interesting findings regarding reindeer and moose saliva. Both reindeer and moose feed on a type of grass called red fescue. Red fescue is usually dangerous to eat due to the presence of a fungus with which it has a mutually beneficial relationship. When the red fescue is eaten, the fungus produces a toxin that decreases blood flow in the legs of the moose and reindeer. This could result in the loss of their limbs.

Since many reindeer and moose successfully feed on red fescue, scientists wondered if their saliva gave them the ability to eat the grass without suffering from circulation problems. Scientists hypothesized that moose and reindeer saliva might detoxify the grass. To conduct their experiment, the researchers smeared reindeer and moose saliva on cut red fescue that contained the fungus. They learned that the saliva slowed the growth of this fungus and detoxified the grass. The results suggest that some animal species have evolved the ability to fight back against a plant's natural defenses.

16-18 Explain the benefit of the ability moose and reindeer have to eat red fescue grass. In your answer, be sure to:

- explain why red fescue plants with the fungus normally have an advantage over red fescue plants without the fungus [1]
- explain how the moose and reindeer saliva protects them from the harmful effects of the fungus [1]
- explain how moose and reindeer (two separate, but related, mammals) could possess the same adaptation that protects them from the toxin produced by the fungus [1]

Base your answer to question 19-21 on the information and photographs below and on your knowledge of biology.

In addition to their use for hearing, ears contain many blood vessels that allow heat to escape into the air. Animals that live in warm climates tend to have ears with large areas exposed to the environment. Animals in cold climates have a more compact ear that keeps exposure to the environment to a minimum. The photographs below show a jackrabbit from desert regions of the southwestern United States and a fennec fox from northern Africa with large ears, and a snowshoe hare and an arctic fox with small ears.



Jackrabbit



Fennec Fox



Snowshoe Hare



Arctic Fox

19-21 Discuss how differences in ear size in these organisms might have occurred. In your answer, be sure to:

- explain how the size of these animals' ears can help the animals survive in their environment [1]
- identify one process that most likely resulted in the animals in warm climates having large ears, while animals in cold climates have small ears [1]
- state how the overproduction of offspring in each species for many generations contributed to the presence of different ear sizes [1]

Base your answers to questions 22 on the passage below and on your knowledge of biology.

Ocean-dwelling (marine) iguanas and land iguanas inhabit the Galapagos Islands. Some scientists believe that both types of iguanas diverged from a common ancestor. Marine iguanas eat algae. Land iguanas feed on cacti. Algae are more abundant in the ocean than cacti are on the islands. Both species lay their eggs in the sand.

Rats, cats, and goats have been introduced to the islands by humans. Rats feed on iguana eggs, cats eat baby iguanas, and goats eat cacti.

22 Identify the process by which ancestral iguanas developed into the present-day marine iguanas and land iguanas of the Galapagos Islands. [1]

Process: _____

Base your answers to questions 23 on the information and diagram below and on your knowledge of biology. The diagram represents a biological process.

Fossil evidence has demonstrated that birds evolved from a group of small carnivorous dinosaurs. Scientists have hypothesized that some evolved into birds as they filled available niches.

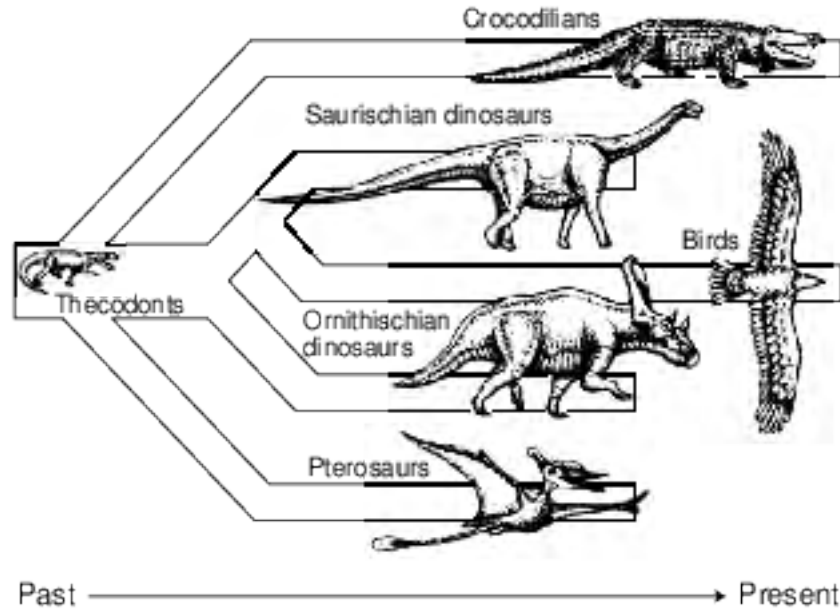

23 Identify two groups of organisms from the diagram that still exist on Earth today. Describe how they may have been able to survive to the present. [1]

Answer Keys

1 1

2 3

3 2

4 1

5 4

6 1

7 4

8 1

9 2

10-14 The student's response to the bulleted items in the question need not appear in the following order.

- 10. Allow 1 credit for identifying one biological process by which a population of this variety may develop resistance. Acceptable responses include, but are not limited to:
 - — natural selection
 - — evolution
 - — reproduction
 - — mutation
- 11. Allow 1 credit for describing how this process is involved in the production of a population of resistant organisms. Acceptable responses include, but are not limited to:
 - Natural Selection:
 - — The population had some members that were naturally resistant to antibiotics. They survived and reproduced, passing on the resistance.
 - Evolution:
 - — Some organisms were resistant to the pesticide. They survived and passed on the trait.
 - Reproduction:
 - — Resistant members survived and passed on the trait.
 - Mutation:
 - — It produces variations that give some organisms a survival advantage.
- Note: Allow credit for a response consistent with the process identified in question 10. .
- 13. Allow 1 credit for identifying one problem caused by this resistance. Acceptable responses include, but are not limited to:
 - — Resistant bacteria will survive and continue to make people sick.
 - — Insects will continue to destroy crops.
 - — Antibiotics do not work anymore.
 - — There will be less food available.
- 14. Allow 1 credit for stating one solution to this problem. Acceptable responses include, but are not limited to:
 - — Do not use antibiotics/antibacterial products unless needed.
 - — Use different antibiotics or pesticides.
 - — Use a natural predator for pests.
 - — Insert genes into plants that will make them resistant to bacteria or pests.
 - — Research and find new antibiotics/ways of controlling insect pests.
- Note: Allow credit for a response consistent with the problem identified in question 13. .
- 16. Allow 1 credit for identifying one possible negative effect of this solution. Acceptable responses include, but are not limited to:
 - — People might be sick longer.
 - — More people could get sick.
 - — Organisms may become resistant to other treatments.
 - — Natural predators may get out of control.
 - — Inserted genes may have an undesired effect.
 - — Research takes a lot of time and money.
- Note: Allow credit for a response consistent with the student's solution to question 14. .

15 Allow 1 credit. Acceptable responses include, but are not limited to:

- — They lacked adaptations to the changing environmental conditions.
- — They were unable to compete for food or other resources.
- — They did not have the variations required for survival in their environment.

16-18 The student's response to the bulleted items in the question need not appear in the following order.

- 16. Allow 1 credit for explaining why red fescue plants with the fungus normally have an advantage over red fescue plants without the fungus. Acceptable responses include, but are not limited to:
 - — The plants with the fungus contain the toxin that usually keeps them from being eaten.
 - — Plants with the fungus are poisonous to most animals that eat them. Plants without the fungus will be eaten readily by many herbivores with no negative effects.
 - — The fungus produces a toxin that is harmful to some animals that eat the red fescue grass.
 - — because it is toxic
 - — It may not be eaten by reindeer or moose.
- 17. Allow 1 credit for explaining how the moose and reindeer saliva protects them from the harmful effects of the fungus. Acceptable responses include, but are not limited to:
 - — The saliva slows down fungus growth.
 - — The saliva helps detoxify the grass.
 - — The saliva helps detoxify the fungus/poison.
- 18. Allow 1 credit for explaining how the moose and reindeer could possess the same adaptation that protects them from the toxin produced by the fungus. Acceptable responses include, but are not limited to:
 - — The two species have a common ancestor that had the adaptation.
 - — The same genetic mutation occurred independently in each species.
 - — The ancestors of the two animals may have each had a different mutation that happened to protect them against the fungus toxin.
 - — The two species are related.
 - — It is the result of convergent evolution.

19-21 The student's response to the bulleted items in the question need not appear in the following order.

- 19. Allow 1 credit for explaining how the size of these animals' ears can help the animals survive in their environment. Acceptable responses include, but are not limited to:
 - — Large ears can help an animal remove excess heat in a warm environment, which helps the animal maintain a stable internal temperature.
 - — The small ears in the arctic fox help minimize heat loss in its cold environment.
 - — The large ears in the jackrabbit let excess heat escape, helping it stay cool.
 - — Large ears would allow animals to hear predators.
- 20. Allow 1 credit for identifying one process that most likely resulted in the animals in warm climates having large ears, while animals in cold climates have small ears. Acceptable responses include, but are not limited to:
 - — natural selection
 - — evolution
 - — mutation
 - — recombination
- 21. Allow 1 credit for stating how the overproduction of offspring in each species for many generations contributed to the presence of different ear sizes. Acceptable responses include, but are not limited to:
 - — When there is overproduction, not all can live, so natural selection results in the survival of the fittest in each generation.
 - — With more offspring, only some survive and pass on their traits, resulting in changes in the species over time.
 - — Overpopulation leads to an increase in the number of variations in a population.
 - — With more individuals, more variations might occur.

22 Allow 1 credit. Acceptable responses include, but are not limited to:

- — evolution/natural selection
- — adaptive radiation
- — speciation

- 23 Allow 1 credit for identifying crocodilians and birds and for describing how they may have been
- able to survive to the present. Acceptable responses include, but are not limited to:
 - — The crocodilians/crocodiles and birds may have survived because they had certain
 - adaptations that allowed them to be successful in their environment then and now.
 - — They had characteristics that allowed them to survive, reproduce, and pass their traits on to
 - their offspring.
 - — They had adaptations to their environments that allowed them to fill available niches.